

Asia and Europe

A7/4 & 7/13, Electro Steel Compound
S.S.G.T. Road Industrial Area,
Ghaziabad, (U.P) 201001 India

T: +(91) 120 4307787-94

F: +(91) 120 4225057, 4307795

E: info@kisaandietech.com
sales@kisaandietech.com

www.kisaandietech.com

North America

1554 Carling Avenue, Suite 046
Ottawa, Ontario, Canada K1Z 7M4

T: +1(613) 406.7391

E: varora@kisaandietech.com
mkellen@kisaandietech.com

www.kisaandietech.com

> Building Trust > Forging Solutions

ASME B16.5

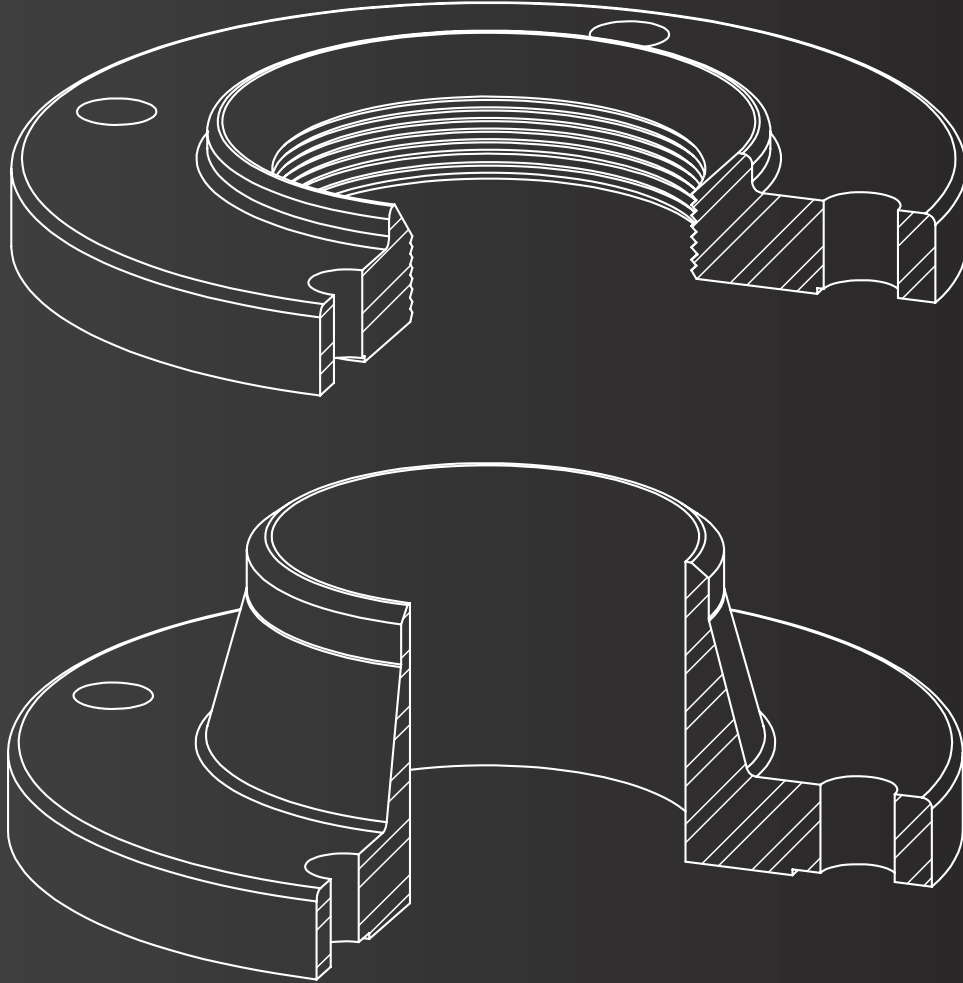

Pipe Flanges and Flanged Fittings

NPS 1/2 Through NPS 24 Inch Standard



ENLISTMENT



CERTIFICATION



CERTIFICATION



CERTIFICATION



CERTIFICATION

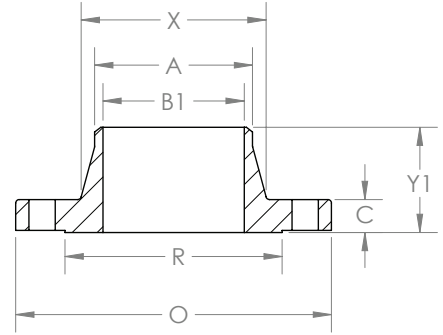
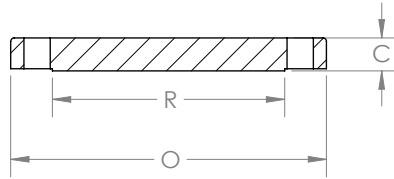
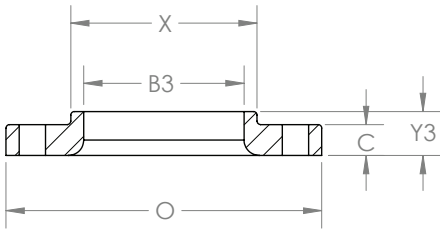
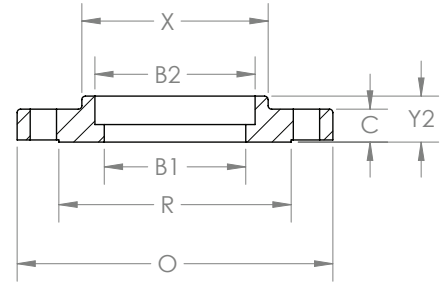
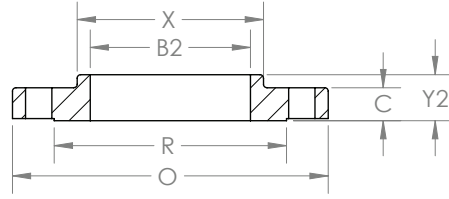
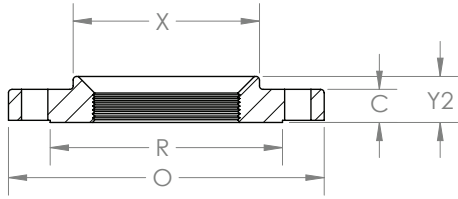

Nominal Size	Outside Diameter	Thickness	Raised Face Diameter	BORE			LENGTH THROUGH HUB			Dia. Hub at Bevel	Hub Dia	Bolt Circle	No. of Holes and Hole Dia.
				Welding Neck/Socket	Slip-On	Lap Joint	Welding Neck/socket	Slip-On/Socket	Lap Joint				
	O	T	R	B1	B2	B3	Y1	Y2	Y3	A	X		
1/2"	3.5	0.38	1.38	0.62	0.88	0.90	1.81	0.56	0.62	0.84	1.19	2.38	4 x 5/8
3/4"	3.88	0.44	1.69	0.82	1.09	1.11	2.00	0.56	0.62	1.05	1.50	2.75	4 x 5/8
1"	4.25	0.5	2.00	1.05	1.36	1.38	2.12	0.62	0.69	1.32	1.94	3.12	4 x 5/8
1-1/4"	4.62	0.56	2.50	1.38	1.70	1.72	2.19	0.75	0.81	1.66	2.31	3.50	4 x 5/8
1-1/2"	5	0.62	2.88	1.61	1.95	1.97	2.38	0.81	0.88	1.90	2.56	3.88	4 x 5/8
2"	6	0.69	3.62	2.07	2.44	2.46	2.44	0.94	1.00	2.38	3.06	4.75	4 x 3/4
2-1/2"	7	0.81	4.12	2.47	2.94	2.97	2.69	1.06	1.12	2.88	3.56	5.50	4 x 3/4
3"	7.5	0.88	5.00	3.07	3.57	3.60	2.69	1.12	1.19	3.50	4.25	6.00	4 x 3/4
3-1/2"	8.5	0.88	5.50	3.55	4.07	4.10	2.75	1.19	1.25	4.00	4.81	7.00	8 x 3/4
4"	9	0.88	6.19	4.03	4.57	4.60	2.94	1.25	1.31	4.50	5.31	7.50	8 x 3/4
5"	10	0.88	7.31	5.05	5.66	5.69	3.44	1.38	1.44	5.56	6.44	8.50	8 x 7/8
6"	11	0.94	8.50	6.07	6.72	6.75	3.44	1.50	1.56	6.63	7.56	9.50	8 x 7/8
8"	13.5	1.06	10.62	7.98	8.72	8.75	3.94	1.69	1.75	8.63	9.69	11.75	8 x 7/8
10"	16	1.12	12.75	10.02	10.88	10.92	3.94	1.88	1.94	10.75	12.00	14.25	12 x 1
12"	19	1.19	15.00	12.00	12.88	12.92	4.44	2.12	2.19	12.75	14.38	17.00	12 x 1
14"	21	1.31	16.25	***	14.14	14.18	4.94	2.19	3.12	14.00	15.75	18.75	12 x 1-1/8
16"	23.5	1.38	18.50	***	16.16	16.19	4.94	2.44	3.44	16.00	18.00	21.25	16 x 1-1/8
18"	25	1.5	21.00	***	18.18	18.20	5.44	2.62	3.81	18.00	19.88	22.75	16 x 1-1/4
20"	27.5	1.62	23.00	***	20.20	20.25	5.62	2.81	4.06	20.00	22.00	25.00	20 x 1-1/4
24"	32	1.81	27.25	***	24.25	24.25	5.94	3.19	4.38	24.00	26.12	29.50	20 x 1-3/8

***=Specified by Purchaser

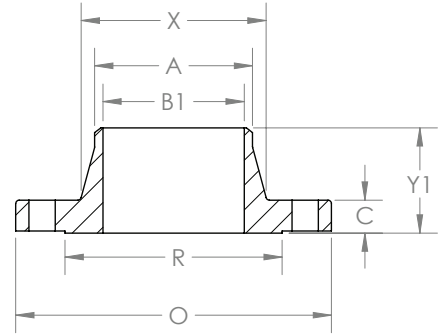
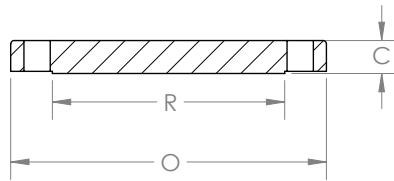
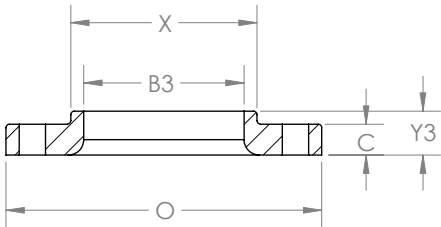
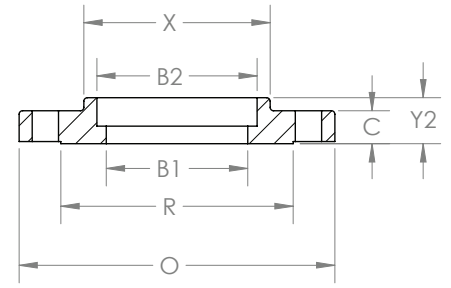
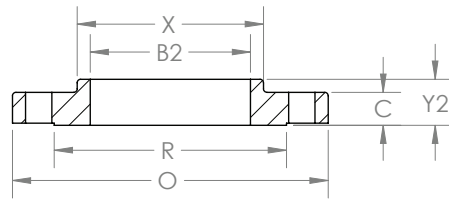
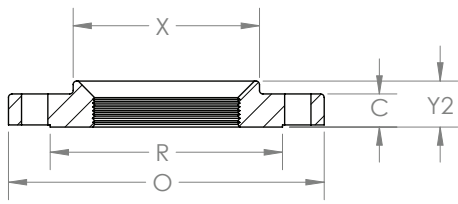

Nominal Size	Outside Diameter	Thickness	Raised Face Diameter	BORE			LENGTH THROUGH HUB			Dia. Hub at Bevel	Hub Dia	Bolt Circle	No. of Holes and Hole Dia.
				Welding Neck/Socket	Slip-On	Lap Joint	Welding Neck/socket	Slip-On/Socket	Lap Joint				
	O	T	R	B1	B2	B3	Y1	Y2	Y3	A	X		
1/2"	3.75	0.56	1.38	0.62	0.88	0.88	2.00	0.81	0.88	0.84	1.50	2.62	4 x 5/8
3/4"	4.62	0.62	1.69	0.82	1.09	1.09	2.19	0.94	1.00	1.05	1.88	3.25	4 x 3/4
1"	4.88	0.69	2.00	1.05	1.36	1.36	2.38	1.00	1.06	1.32	2.12	3.50	4 x 3/4
1-1/4"	5.25	0.75	2.50	1.38	1.70	1.70	2.50	1.00	1.06	1.66	2.50	3.88	4 x 3/4
1-1/2"	6.12	0.81	2.88	1.61	1.95	1.95	2.63	1.13	1.19	1.90	2.75	4.50	4 x 7/8
2"	6.50	0.88	3.62	2.07	2.44	2.44	2.69	1.25	1.31	2.38	3.31	5.00	8 x 3/4
2-1/2"	7.50	1.00	4.12	2.47	2.94	2.94	2.94	1.44	1.50	2.88	3.94	5.88	8 x 7/8
3"	8.25	1.12	5.00	3.07	3.57	3.57	3.06	1.63	1.69	3.50	4.62	6.62	8 x 7/8
3-1/2"	9.00	1.19	5.50	3.55	4.07	4.07	3.13	1.69	1.75	4.00	5.25	7.25	8 x 7/8
4"	10.00	1.25	6.19	4.03	4.57	4.57	3.32	1.82	1.88	4.50	5.75	7.88	8 x 7/8
5"	11.00	1.38	7.31	5.05	5.66	5.66	3.82	1.94	2.00	5.56	7.00	9.25	8 x 7/8
6"	12.50	1.44	8.50	6.07	6.72	6.72	3.82	2.00	2.06	6.63	8.12	10.62	12 x 7/8
8"	15.00	1.62	10.62	7.98	8.72	8.72	4.32	2.38	2.44	8.63	10.25	13.00	12 x 1
10"	17.50	1.88	12.75	10.02	10.88	10.88	4.56	2.56	3.75	10.75	12.62	15.25	16 x 1-1/8
12"	20.50	2.00	15.00	12.00	12.88	12.88	5.06	2.82	4.00	12.75	14.75	17.75	16 x 1-1/4
14"	23.00	2.12	16.25	***	14.14	14.14	5.56	2.94	4.38	14.00	16.75	20.25	20 x 1-1/4
16"	25.50	2.25	18.50	***	16.16	16.16	5.69	3.19	4.75	16.00	19.00	22.50	20 x 1-3/8
18"	28.00	2.38	21.00	***	18.18	18.18	6.19	3.44	5.12	18.00	21.00	24.75	24 x 1-3/8
20"	30.50	2.50	23.00	***	20.20	20.20	6.32	3.69	5.50	20.00	23.12	27.00	24 x 1-3/8
24"	36.00	2.75	27.25	***	24.25	24.25	6.56	4.13	6.00	24.00	27.62	32.00	24 x 1-5/8

***=Specified by Purchaser

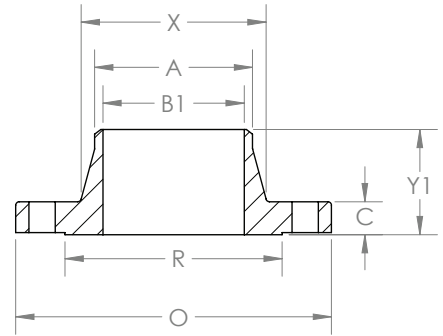
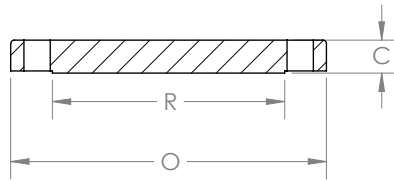
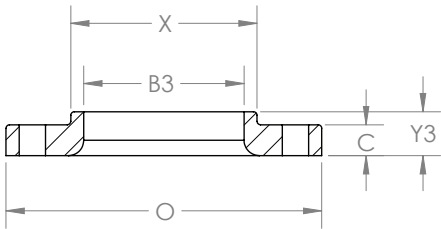
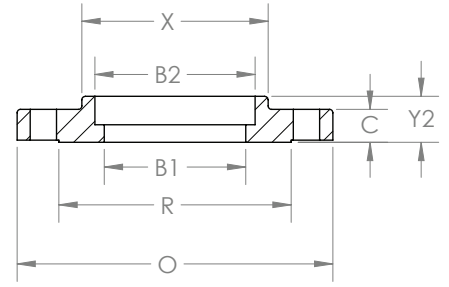
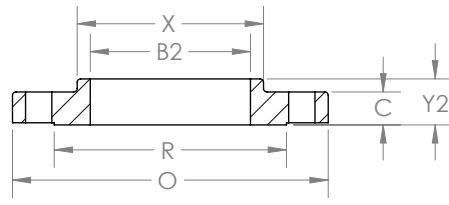
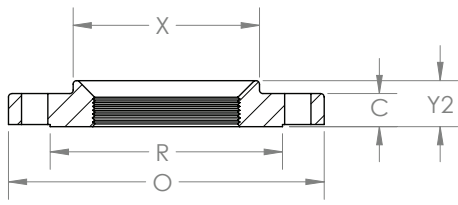

Nominal Size	Outside Diameter	Thickness	Raised Face Diameter	BORE			LENGTH THROUGH HUB			Dia. Hub at Bevel	Hub Dia	Bolt Circle	No. of Holes and Hole Dia.
				Welding Neck/Socket	Slip-On	Lap Joint	Welding Neck/socket	Slip-On/Socket	Lap Joint				
	O	T	R	B1	B2	B3	Y1	Y2	Y3	A	X		
1/2"	3.75	0.56	1.38	***	0.88	0.90	2.06	0.88	0.88	0.84	1.50	2.62	4 x 5/8
3/4"	4.62	0.62	1.69	***	1.09	1.11	2.25	1.00	1.00	1.05	1.88	3.25	4 x 3/4
1"	4.88	0.69	2.00	***	1.36	1.38	2.44	1.06	1.06	1.32	2.12	3.50	4 x 3/4
1-1/4"	5.25	0.81	2.50	***	1.70	1.72	2.62	1.12	1.12	1.66	2.50	3.88	4 x 3/4
1-1/2"	6.12	0.88	2.88	***	1.95	1.97	2.75	1.25	1.25	1.90	2.75	4.50	4 x 7/8
2"	6.50	1.00	3.62	***	2.44	2.46	2.88	1.44	1.44	2.38	3.31	5.00	8 x 3/4
2-1/2"	7.50	1.12	4.12	***	2.94	2.97	3.12	1.62	1.62	2.88	3.94	5.88	8 x 7/8
3"	8.25	1.13	5.00	***	3.57	3.60	3.25	1.81	1.81	3.50	4.62	6.62	8 x 7/8
3-1/2"	9.00	1.38	5.50	***	4.07	4.10	3.38	1.94	1.94	4.00	5.25	7.25	8 x 1
4"	10.00	1.38	6.19	***	4.57	4.60	3.50	2.00	2.12	4.50	5.75	7.88	8 x 1
5"	11.00	1.50	7.31	***	5.66	5.69	4.00	2.12	2.38	5.56	7.00	9.25	8 x 1
6"	12.50	1.62	8.50	***	6.72	6.75	4.06	2.25	2.62	6.63	8.12	10.62	12 x 1
8"	15.00	1.88	10.62	***	8.72	8.75	4.62	2.69	3.00	8.63	10.25	13.00	12 x 1-1/8
10"	17.50	2.12	12.75	***	10.88	10.92	4.88	2.88	4.38	10.75	12.62	15.25	16 x 1-1/4
12"	20.50	2.25	15.00	***	12.88	12.92	5.38	3.12	4.62	12.75	14.75	17.75	16 x 1-3/8
14"	23.00	2.38	16.25	***	14.14	14.18	5.88	3.31	5.00	14.00	16.75	20.25	20 x 1-3/8
16"	25.50	2.50	18.50	***	16.16	16.19	6.00	3.69	5.50	16.00	19.00	22.50	20 x 1-1/2
18"	28.00	2.62	21.00	***	18.18	18.20	6.50	3.88	6.00	18.00	21.00	24.75	24 x 1-1/2
20"	30.50	2.75	23.00	***	20.20	20.25	6.62	4.00	6.50	20.00	23.12	27.00	24 x 1-5/8
24"	36.00	3.00	27.25	***	24.25	24.25	6.88	4.50	7.25	24.00	27.62	32.00	24 x 1-7/8

***=Specified by Purchaser

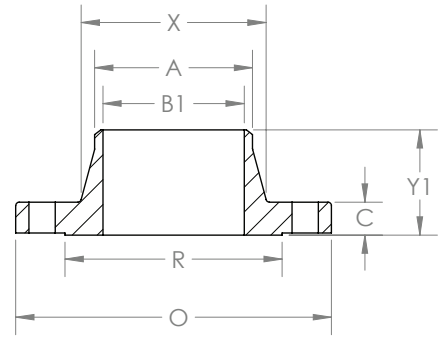
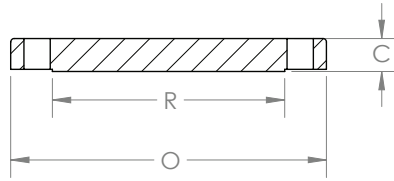
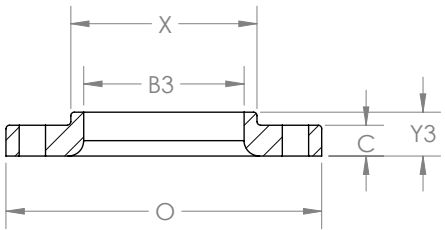
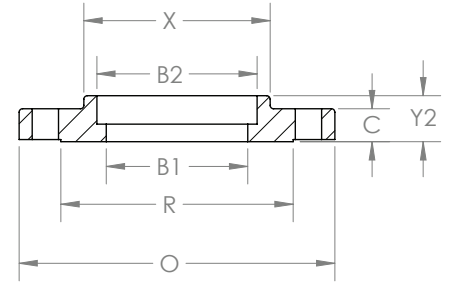
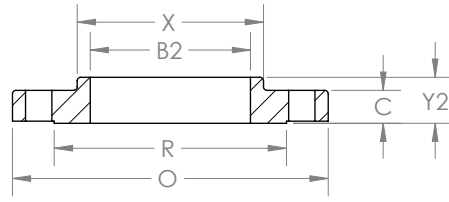
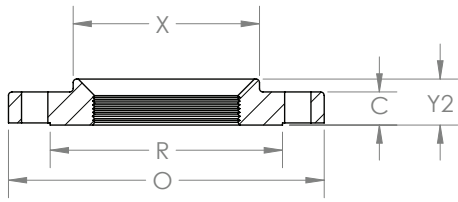

Nominal Size	Outside Diameter	Thickness	Raised Face Diameter	BORE			LENGTH THROUGH HUB			Dia. Hub at Bevel	Hub Dia	Bolt Circle	No. of Holes and Hole Dia.
				Welding Neck/Socket	Slip-On	Lap Joint	Welding Neck/socket	Slip-On/Socket	Lap Joint				
	O	T	R	B1	B2	B3	Y1	Y2	Y3	A	X		
1/2"	3.75	0.56	1.38	***	0.88	0.90	2.06	0.88	0.88	0.84	1.50	2.62	4 x 5/8
3/4"	4.62	0.62	1.69	***	1.09	1.11	2.25	1.00	1.00	1.05	1.88	3.25	4 x 3/4
1"	4.88	0.69	2.00	***	1.36	1.38	2.44	1.06	1.06	1.32	2.12	3.50	4 x 3/4
1-1/4"	5.25	0.81	2.50	***	1.70	1.72	2.62	1.12	1.12	1.66	2.50	3.88	4 x 3/4
1-1/2"	6.12	0.88	2.88	***	1.95	1.97	2.75	1.25	1.25	1.90	2.75	4.50	4 x 7/8
2"	6.50	1.00	3.62	***	2.44	2.46	2.88	1.44	1.44	2.38	3.31	5.00	8 x 3/4
2-1/2"	7.50	1.12	4.12	***	2.94	2.97	3.12	1.62	1.62	2.88	3.94	5.88	8 x 7/8
3"	8.25	1.13	5.00	***	3.57	3.60	3.25	1.81	1.81	3.50	4.62	6.62	8 x 7/8
3-1/2"	9.00	1.38	5.50	***	4.07	4.10	3.38	1.94	1.94	4.00	5.25	7.25	8 x 1
4"	10.75	1.50	6.19	***	4.57	4.60	4.00	2.12	2.12	4.50	6.00	8.50	8 x 1
5"	13.00	1.75	7.31	***	5.66	5.69	4.50	2.38	2.38	5.56	7.44	10.50	8 x 1-1/8
6"	14.00	1.88	8.50	***	6.72	6.75	4.62	2.62	2.62	6.63	8.75	11.50	12 x 1-1/8
8"	16.50	2.19	10.62	***	8.72	8.75	5.25	3.00	3.00	8.63	10.75	13.75	12 x 1-1/4
10"	20.00	2.50	12.75	***	10.88	10.92	6.00	3.38	4.38	10.75	13.50	17.00	16 x 1-3/8
12"	22.00	2.62	15.00	***	12.88	12.92	6.12	3.62	4.62	12.75	15.75	19.25	20 x 1-3/8
14"	23.75	2.75	16.25	***	14.14	14.18	6.50	3.69	5.00	14.00	17.00	20.75	20 x 1-1/2
16"	27.00	3.00	18.50	***	16.16	16.19	7.00	4.19	5.50	16.00	19.50	23.75	20 x 1-5/8
18"	29.25	3.25	21.00	***	18.18	18.20	7.25	4.62	6.00	18.00	21.50	25.75	20 x 1-3/4
20"	32.00	3.50	23.00	***	20.20	20.25	7.50	5.00	6.50	20.00	24.00	28.50	24 x 1-3/4
24"	37.00	4.00	27.25	***	24.25	24.25	8.00	5.50	7.25	24.00	28.25	33.00	24 x 2

***=Specified by Purchaser

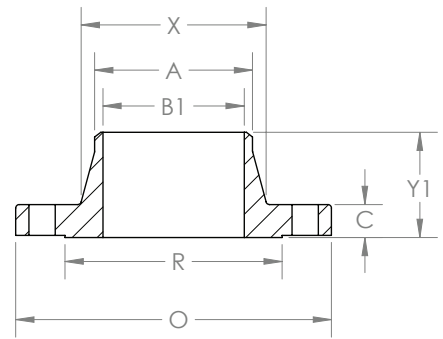
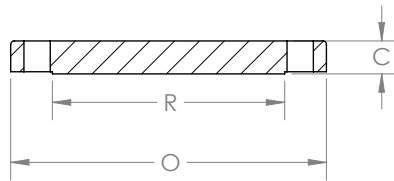
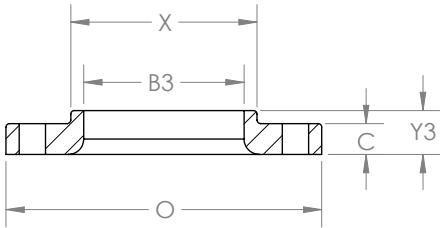
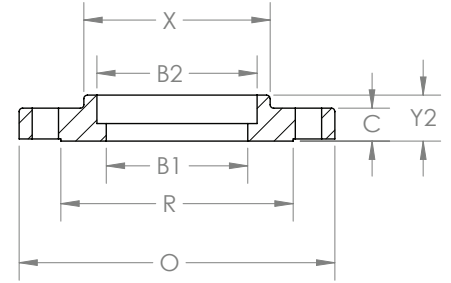
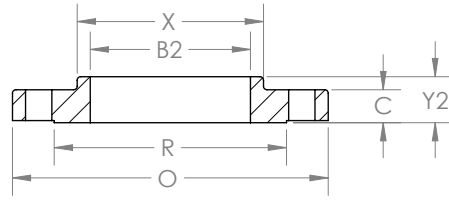
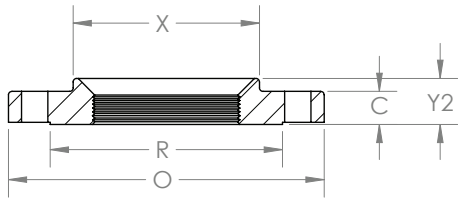

Nominal Size	Outside Diameter	Thickness	Raised Face Diameter	BORE			LENGTH THROUGH HUB			Dia. Hub at Bevel	Hub Dia	Bolt Circle	No. of Holes and Hole Dia.
				Welding Neck/Socket	Slip-On	Lap Joint	Welding Neck/socket	Slip-On/Socket	Lap Joint				
	O	T	R	B1	B2	B3	Y1	Y2	Y3	A	X		
1/2"	4.75	0.88	1.38	***	0.88	0.90	2.38	1.25	1.25	0.84	1.50	3.25	4 x 7/8
3/4"	5.12	1.00	1.69	***	1.09	1.11	2.75	1.38	1.38	1.05	1.75	3.50	4 x 7/8
1"	5.88	1.12	2.00	***	1.36	1.38	2.88	1.62	1.62	1.32	2.06	4.00	4 x 1
1-1/4"	6.25	1.12	2.50	***	1.70	1.72	2.88	1.62	1.62	1.66	2.50	4.38	4 x 1
1-1/2"	7.00	1.25	2.88	***	1.95	1.97	3.25	1.75	1.75	1.90	2.75	4.88	4 x 1-1/8
2"	8.50	1.50	3.62	***	2.44	2.46	4.00	2.25	2.25	2.38	4.12	6.50	8 x 1
2-1/2"	9.62	1.62	4.12	***	2.94	2.97	4.12	2.50	2.50	2.88	4.88	7.50	8 x 1-1/8
3-1/2"	9.50	1.50	5.00	***	3.57	3.60	4.00	2.12	2.12	3.50	5.00	7.50	8 x 1
4"	11.50	1.75	6.19	***	4.57	4.60	4.50	2.75	2.75	4.50	6.25	9.25	8 x 1-1/4
5"	13.75	2.00	7.31	***	5.66	5.69	5.00	3.12	3.12	5.56	7.50	11.00	8 x 1-3/8
6"	15.00	2.19	8.50	***	6.72	6.75	5.50	3.38	3.38	6.63	9.25	12.50	12 x 1-1/4
8"	18.50	2.50	10.62	***	8.72	8.75	6.38	4.00	4.50	8.63	11.75	15.50	12 x 1-1/2
10"	21.50	2.75	12.75	***	10.88	10.92	7.25	4.25	5.00	10.75	14.50	18.50	16 x 1-1/2
12"	24.00	3.12	15.00	***	12.88	12.92	7.88	4.62	5.62	12.75	16.50	21.00	20 x 1-1/2
14"	25.25	3.38	16.25	***	14.14	14.18	8.38	5.12	6.12	14.00	17.75	22.00	20 x 1-5/8
16"	27.75	3.50	18.50	***	16.16	16.19	8.50	5.25	6.50	16.00	20.00	24.25	20 x 1-3/4
18"	31.00	4.00	21.00	***	18.18	18.20	9.00	6.00	7.50	18.00	22.25	27.00	20 x 2
20"	33.75	4.25	23.00	***	20.20	20.25	9.75	6.25	8.25	20.00	24.50	29.50	20 x 2-1/8
24"	41.00	5.50	27.25	***	24.25	24.25	11.50	8.00	10.50	24.00	29.50	35.50	20 x 2-5/8

***=Specified by Purchaser

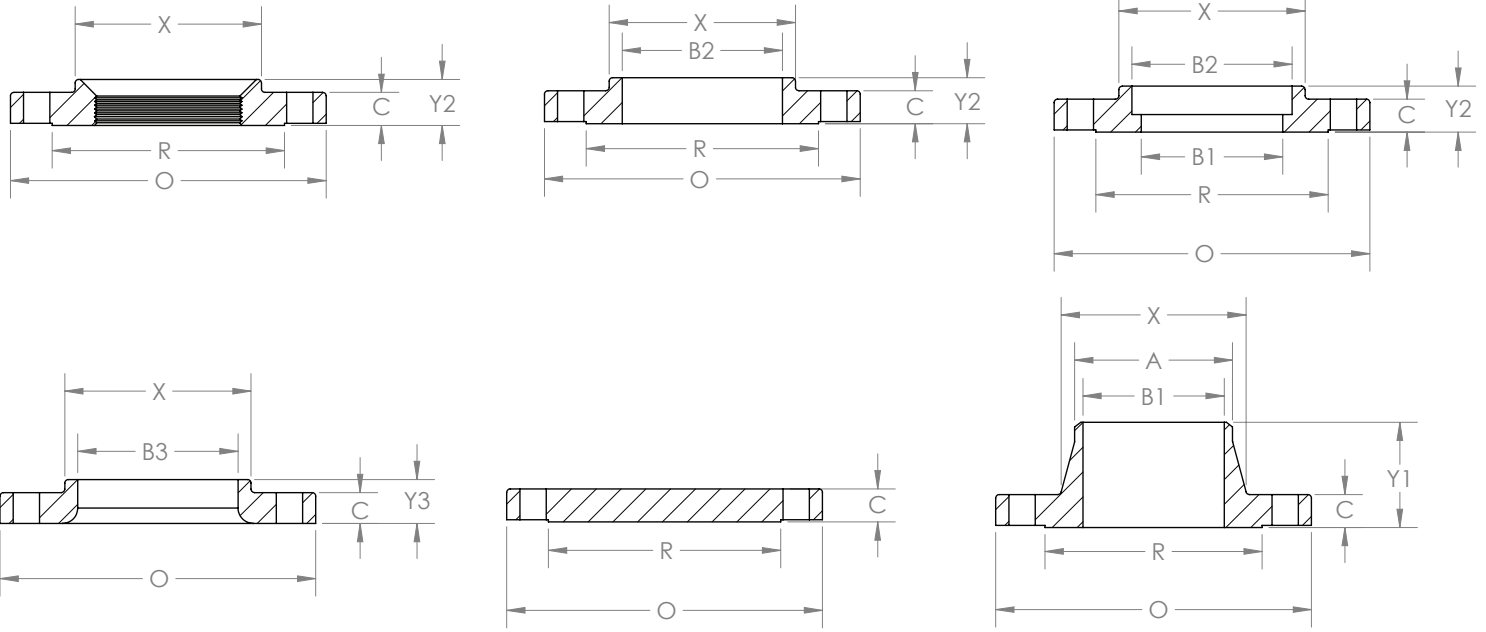

Nominal Size	Outside Diamter	Thickness	Raised Face Diameter	BORE			LENGTH THROUGH HUB			Dia. Hub at Bevel	Hub Dia	Bolt Circle	No. of Holes and Hole Dia.
				Welding Neck/Socket	Slip-On	Lap Joint	Welding Neck/socket	Slip-On/Socket	Lap Joint				
	O	T	R	B1	B2	B3	Y1	Y2	Y3	A	X		
1/2"	4.75	0.88	1.38	***	0.88	0.90	2.38	1.25	1.25	0.84	1.50	3.25	4 x 7/8
3/4"	5.12	1.00	1.69	***	1.09	1.11	2.75	1.38	1.38	1.05	1.75	3.50	4 x 7/8
1"	5.88	1.12	2.00	***	1.36	1.38	2.88	1.62	1.62	1.32	2.06	4.00	4 x 1
1-1/4"	6.25	1.12	2.50	***	1.70	1.72	2.89	1.62	1.62	1.66	2.50	4.38	4 x 1
1-1/2"	7.00	1.25	2.88	***	1.95	1.97	3.25	1.75	1.75	1.90	2.75	4.88	4 x 1-1/8
2"	8.50	1.50	3.62	***	2.44	2.46	4.00	2.25	2.25	2.38	4.12	6.50	8 x 1
2-1/2"	9.62	1.62	4.12	***	2.94	2.97	4.12	2.50	2.50	2.88	4.88	7.50	8 x 1-1/8
3"	10.50	1.88	5.00	***	**	3.60	4.62	**	2.88	3.50	5.25	8.00	8 x 1-1/4
4"	12.25	2.12	6.19	***	**	4.60	4.88	**	3.56	4.50	6.38	9.50	8 x 1-3/8
5"	14.75	2.88	7.31	***	**	5.69	6.12	**	4.12	5.56	7.75	11.50	8 x 1-5/8
6"	15.50	3.25	8.50	***	**	6.75	4.75	**	4.69	6.63	9.00	12.50	12 x 1-1/2
8"	19.00	3.62	10.62	***	**	8.75	8.38	**	5.62	8.63	11.50	15.50	12 x 1-3/4
10"	23.00	4.25	12.75	***	**	10.92	10.00	**	7.00	10.75	14.50	19.00	12 x 2
12"	26.50	4.88	15.00	***	**	12.92	11.12	**	8.62	12.75	17.75	22.50	16 x 2-1/8
14"	29.50	5.25	16.25	***	**	14.18	11.75	**	9.50	14.00	19.50	25.00	16 x 2-3/8
16"	32.50	5.75	18.50	***	**	16.19	12.25	**	10.25	16.00	21.75	27.75	16 x 2-5/8
18"	36.00	6.38	21.00	***	**	18.20	12.88	**	10.88	18.00	23.50	30.50	16 x 2-7/8
20"	38.75	7.00	23.00	***	**	20.25	14.00	**	11.50	20.00	25.25	32.75	16 x 3-1/8
24"	46.00	8.00	27.25	***	**	24.25	16.00	**	13.00	24.00	30.00	39.00	16 x 3-5/8

**=Flange Not available in this size

***=Specified by Purchaser

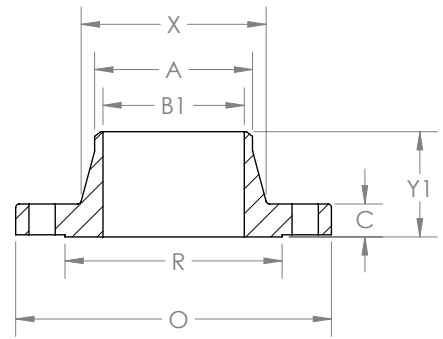
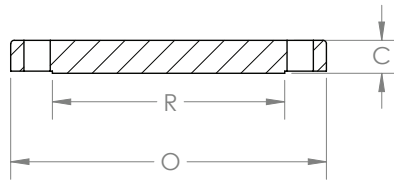
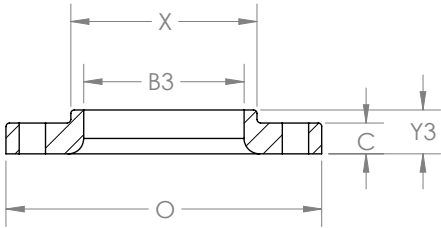
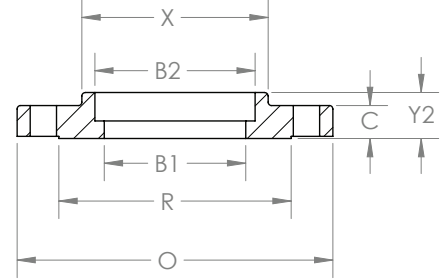
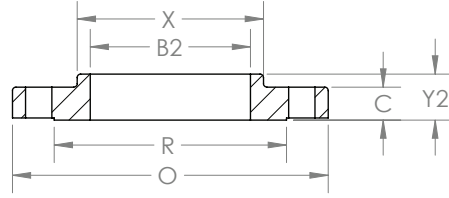
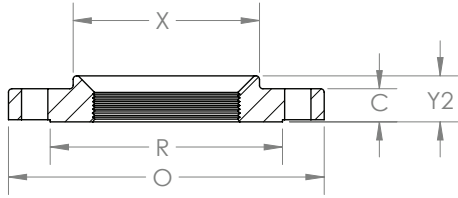

Nominal Size	Outside Diameter	Thickness	Raised Face Diameter	BORE		LENGTH THROUGH HUB		Dia. Hub at Bevel	Hub Dia	Bolt Circle	No. of Holes and Hole Dia.
				Welding Neck	Lap Joint	Welding Neck	Lap Joint				
	0	T	R	B1	B3	Y1	Y3	A	X		
1/2"	5.25	1.19	1.38	***	0.90	2.88	1.56	0.84	1.69	3.50	4 x 7/8
3/4"	5.50	1.25	1.69	***	1.11	3.12	1.69	1.05	2.00	3.75	4 x 7/8
1"	6.25	1.38	2.00	***	1.38	3.50	1.88	1.32	2.25	4.25	4 x 1
1-1/4"	7.25	1.50	2.50	***	1.72	3.75	2.06	1.66	2.88	5.12	4 x 1-1/8
1-1/2"	8.00	1.75	2.88	***	1.97	4.38	2.38	1.90	3.12	5.75	4 x 1-1/4
2"	9.25	2.00	3.62	***	2.46	5.00	2.75	2.38	3.75	6.75	8 x 1-1/8
2-1/2"	10.50	2.25	4.12	***	2.97	5.62	3.12	2.88	4.50	7.75	8 x 1-1/4
3"	12.00	2.62	5.00	***	3.60	6.62	3.62	3.50	5.25	9.00	8 x 1-3/8
4"	14.00	3.00	6.19	***	4.60	7.50	4.25	4.50	6.50	10.75	8 x 1-5/8
5"	16.50	3.62	7.31	***	5.69	9.00	5.12	5.56	8.00	12.75	8 x 1-7/8
6"	19.00	4.25	8.50	***	6.75	10.75	6.00	6.63	9.25	14.50	8 x 2-1/8
8"	21.75	5.00	10.62	***	8.75	12.50	7.00	8.63	12.00	17.25	12 x 2-1/8
10"	26.50	6.50	12.75	***	10.92	16.50	9.00	10.75	14.75	21.25	12 x 2-5/8
12"	30.00	7.25	15.00	***	12.92	18.25	10.00	12.75	17.38	24.39	12 x 2-7/8

***=Specified by Purchaser

Tolerances

Flange Thickness

SIZE	TOLERANCE
NPS ≤ 18	+0.12, -0.00 in
NPS ≥ 20	+0.19, -0.00 in

Length Through Hub on Welding Neck Flanges

SIZE	TOLERANCE
NPS ≤ 4	±0.06 in.
5 ≤ NPS ≤ 10	+0.06, -0.12 in.
NPS ≥ 12	+0.12, -0.18 in.

Bore Diameter, Lapped and Slip-On Flange

SIZE	TOLERANCE
NPS ≤ 10	+0.03, -0.00 in
NPS ≥ 12	+0.06, -0.00 in

Counterbore Diameter, Socket Welding Flange

SIZE	TOLERANCE
1/2 ≤ NPS ≤ 3	±0.010 in.

Bolt Circle Diameter

SIZE	TOLERANCE
N/A	±0.06 in.

Bolt Hole to Bolt Hole

SIZE	TOLERANCE
N/A	±0.03 in.

Bolt Circle Concentricity

SIZE	TOLERANCE
NPS ≤ 2-1/2	0.03 in.
NPS ≥ 3	0.06 in.